

240V ARGO Weatherproof LED Batten Switchable Colour Installation & Maintenance Instruction Leaflet



Designed in Australia to comply with the requirements of
AS2293.3: 2005 and AS/NZS CISPR15: 2017

Victoria (Head Office & Manufacturing)
Website: www.clevertronics.com.au
Email: info@clevertronics.com.au
Phone: +61 3 9559 2700
Fax: +61 3 9559 2799

New South Wales
Phone: +61 2 8805 6400
Fax: +61 2 8805 6444

Queensland
Phone: +61 7 3442 9700
Fax: +61 7 3442 9777

South Australia/Northern Territory
Phone: +61 8 8301 8800
Fax: +61 8 8351 8286

Western Australia
Phone: +61 8 9207 0000
Fax: +61 8 9207 0088

New Zealand
Phone: +64 800 548 448

Models: ARGO-600-xxx-yy-zz

Options:

Microwave Sensor (HI/LO) xxx = SEN
ZW Inline Filter yy = FLT
Flat Earth Flex/Plug zz = FPF

Spare Parts:

1330086-A LED Driver - 20w Stallion S-MNT
1330087-A LED Driver - 20w Stallion S-MNT,MS-HL (SEN version only)

Important:

It is illegal for anyone, except for a licensed electrician to install or maintain this product. Before installation, ensure that the electricity supply has been switched off and isolated. Installation must be carried out in accordance with the relevant Australian and International Standards.

Installation:

This product can be mounted to any solid surface. Please follow the below installation steps:

- Determine the installation method (surface/surface with clips).
- Determine the power entry method.
- Undo the Diffuser Clips, remove the Diffuser and Gear Tray. Position the batten base in the desired location.
- Mark out the fixing points on the mounting surface.
- If the cable entry is to be via the rear of the body – Drill out a suitable entry-hole in the rear of the batten body (must be suitably sealed after cable entry using a sealant). If the cable entry is via the end of the batten - Install the provided cable gland, or bring in conduit, to the base as required for the intended power access.
Note: Only round cables are to be used with the cable gland for an IP65 seal. Keep cable entry straight and tension free. Ensure all seals are tight.
min. wire diameter 7mm, max. 12mm.
- **For surface mounting** -, there are 2 extrusions/posts at each end of the base. Drill out the desired number of fixing points at each end. **Fixings must only be through the extrusions/mounting posts.**
 - Position the fitting to the mounting surface and mark the mounting holes.
 - Cable/Gland entry to be down if mounting vertically.
 - Drill the mounting holes.
 - Fix the base to the surface with appropriate fixings.
 - Seal any penetrations/fixing points with appropriate sealant.
- **For Surface Mount Clip mounting**, measure/mark spacing (see dimensions below), install stainless steel clips to surface (use appropriate fixings), then snap batten into clips.
- Wire mains power cable, 240V 50Hz, to terminals marked A, N & 
- Set Colour Switch to the desired colour (3000K, 4000K, 5700K)
- Attach Gear Tray to lanyards.
- Reinstall the Gear Tray.
- Reinstall the Diffuser and latch the Diffuser Clips.

Note:

This luminaire (with reinforced insulation between control/LED terminal and AC Supply) contains non-user replaceable light source – to be replaced (if required) by the manufacturer or his service agent or a similar qualified person.

Dimensions:

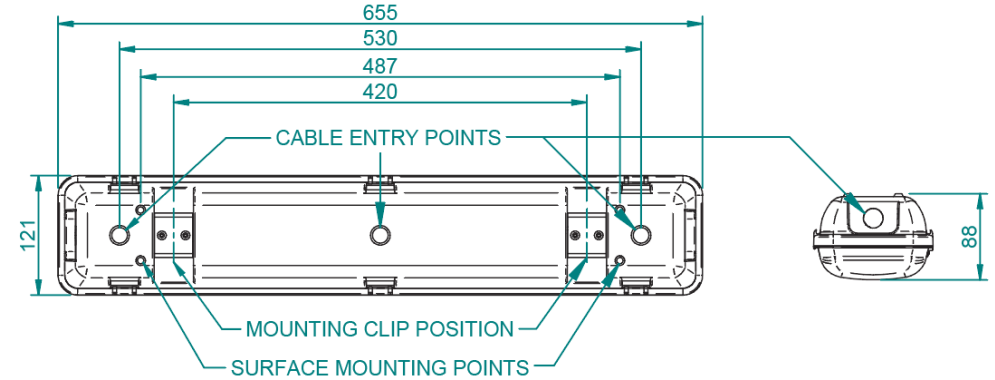

Colour Setting:

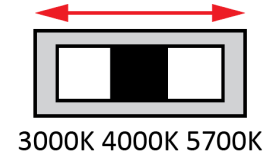

Gear Tray Clip:

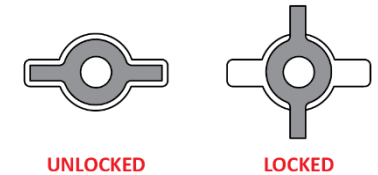

Trouble Shooting:

Below are a list of common problems and their possible causes.

Fault: The Green LED Test Switch indicator is not illuminated.

Check: A.C. is connected and is turned on.
Battery is connected
Test Switch for damage.

Fault: Lamp does not illuminate in emergency mode.

Check: A.C. is connected.
Lamp is correctly inserted.
Battery is connected

Fault: Lamp illuminates in emergency mode, but only stays on for a short period.

Check: Battery has been allowed to charge for at least 24 hours.
Battery for damage.

Warranty:

For Product Warranty information and Terms and Conditions of Sales please refer to our website <http://clevertronics.com.au/terms-conditions-sale-australia-nz/>